

VARYCONTROL Plastic VAV Controller

for aggressive media
Type TVRK

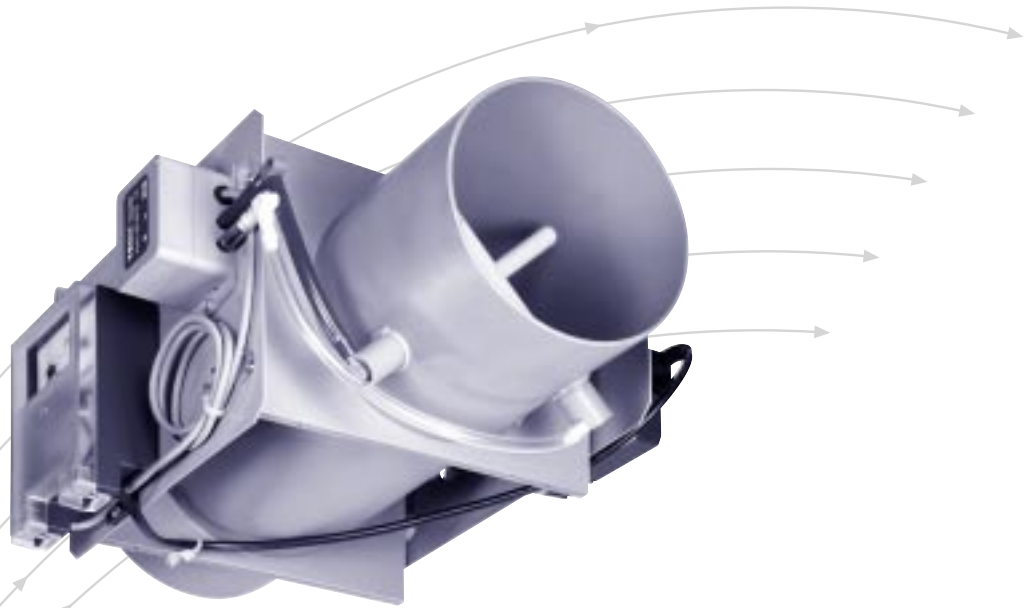

TROX[®] TECHNİK

The art of handling air

Contents · Description

Description _____	2	Aerodynamic and acoustic quick selection _____	6
Construction · Dimensions _____	3	Air-regenerated noise _____	7
Nomenclature · Dimensions · Weight _____	4	Case-radiated noise _____	8
Functional description _____	5	Order details _____	9

VAV controller type TVRK

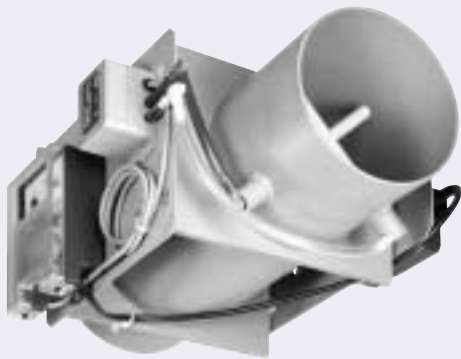

VAV controller type TVRK, construction with flanges

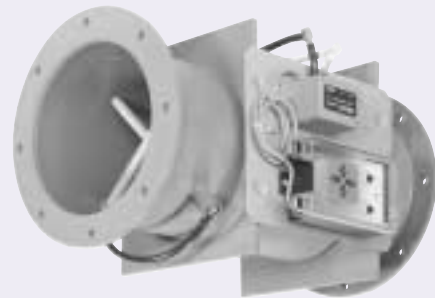

TROX VARYCONTROL VAV controllers, Type TVRK, have been developed for the control of air flow, especially for variable extract air flow systems handling aggressive media.

The mechanical components and electronic control components which are factory fitted, form the controls package. Every controller is factory tested and set to the required flow rates.

The unit consists of a removable (slide out) averaging differential pressure sensor for air flow measurement and a control damper. The damper blade with plastic seal when closed complies with the air tightness requirements of DIN EN 1751. There are circular spigot connections on both ends. A construction with flanges on both ends is available.

When low noise levels are required a plastic circular silencer Type CAK should be used.

The flow rate control is a closed loop system with auxiliary power supply. Transducer, controller and actuator are selected according to the operational and control requirements. TROX VAV terminal units can be supplied with control components from any reputable manufacturer to suit a project specification.

Further, current information on application, selection as well as control components available can be found in the “Technical Documents” download area of our website. Also available on the internet is the on-line design programme “air terminal units” for the design and selection of our units.

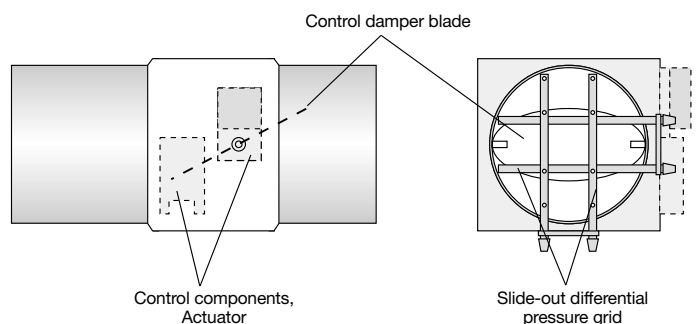

Construction · Dimensions

Characteristics

- Electronic flow rate control
- Suitable for supply or extract air
- Flow rate control range approx. 7 : 1, depending on type of controller
- High level of control accuracy for the flow rate settings, even if there is an elbow connection $R = 1 D$
Please ensure the most favourable aerodynamic configuration of ductwork is used
- Differential pressure range 20 to 1500 Pa
- Shut-off by switching (control switch by others)
- Installation orientation must be as shown on the label
- Control damper closed blade leakage complies with DIN EN 1751, class 3
- Factory set up of flow rate. This includes aerodynamic function test of each unit using a dedicated test rig. Data covering set up is given on a test label attached to each unit
- Flow rate can be measured and subsequently reset on site; an additional adjustment tool may be necessary
- Actual value signal referred to nominal flow rate
- The mechanical components are maintenance-free
- Operating temperature range 10 to 50 °C

Constructional features

- Both ends same size (standard construction)
- Option both ends with flanges
- Casing air leakage complies with DIN EN 1751, class B

Materials

- Casing and damper blade in flame resistant polypropylene (PPs)
- Plain bearings in polypropylene (PP)
- Damper blade seals in chloroprene rubber (CR)
- Removable (slide out) differential pressure grid in plastic (PP)

The materials used have been selected for their proven suitability in use. Please note that in critical cases, material compatibility testing should be carried out on the air terminal unit and the diaphragm pressure transducer, taking into consideration the harmful substances involved and the concentrations in which they occur.

TVRK, Nominal size 125... 200

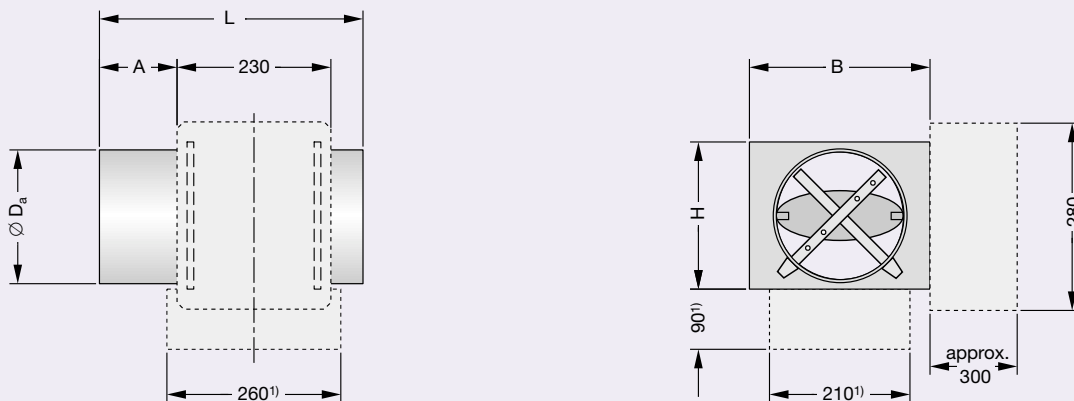

TVRK, Nominal size 250... 400

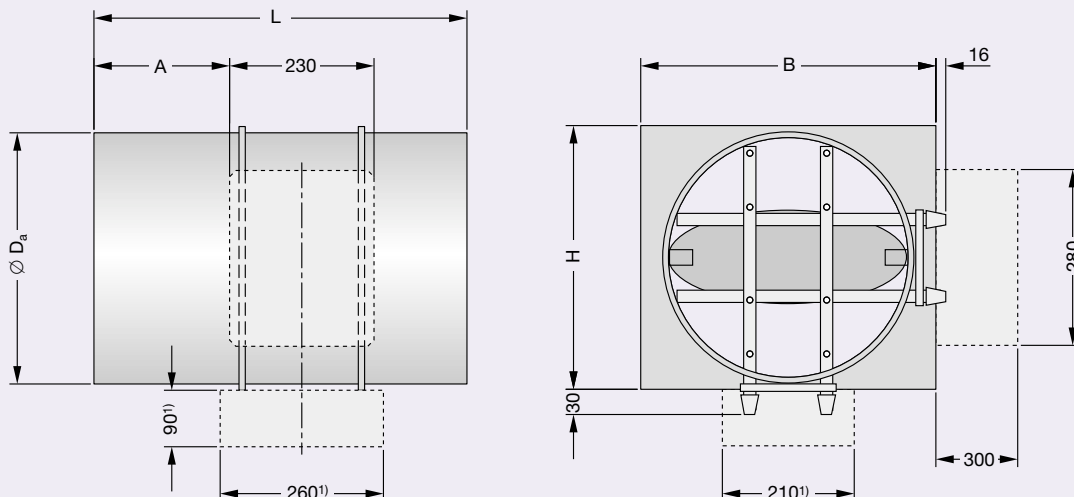

--- Keep clear to provide access to control components

1) Additionally for control components order code T...

Nomenclature · Dimensions · Weight

Nomenclature

f_m	in Hz:	Octave band centre frequency
L_W	in dB:	Sound power level of the air-regenerated noise in the ducting
L_{W2}	in dB:	Sound power level of the case-radiated noise
L_{pA}	in dB(A):	A-weighted sound pressure level of air-regenerated noise in the room, system attenuation taken into account
L_{pA1}	in dB(A):	A-weighted sound pressure level of air-regenerated noise in the room with CAK circular silencer, system attenuation taken into account
L_{pA2}	in dB(A):	A-weighted sound pressure level of case-radiated noise in the room, system attenuation taken into account
\dot{V}_{nom}	in m ³ /h or l/s:	Nominal flow rate (100 %)
\dot{V}	in m ³ /h or l/s:	Flow rate
$\Delta \dot{V}$	in ± %:	Flow rate tolerance from setpoint value
Δp_g	in Pa:	Total pressure differential
Δp_{gmin}	in Pa:	Minimum total pressure differential

All sound power levels are based on 1 pW, all sound pressure levels on 20 µPa.

All noise levels determined in a reverberation chamber. The sound power data was determined and corrected according to DIN EN ISO 5135, February 1999.

TVRK, flange construction

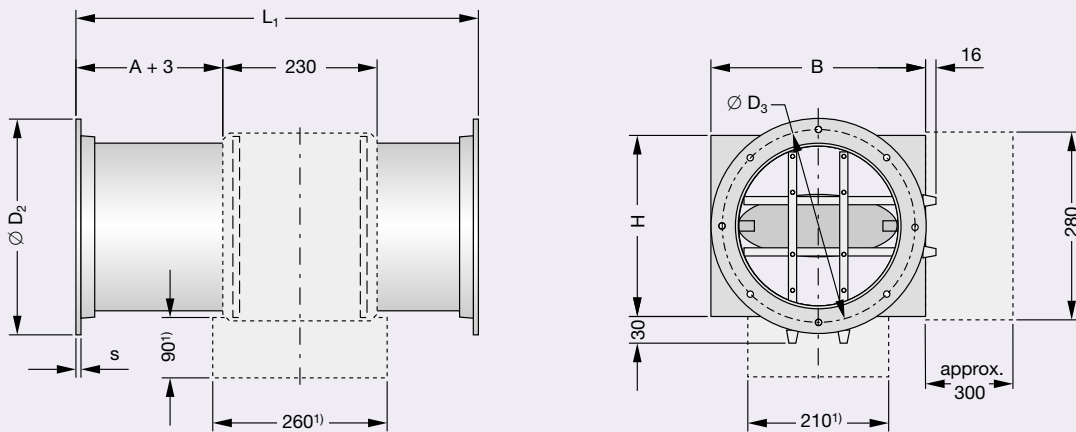

--- Keep clear to provide access to control components

1) Additionally for control components order code T...

Nominal size	Dimensions in mm											Weight in kg	
	Ø D _a	Ø D ₂	Ø D ₃	Ø d	L	L ₁	B	H	A	n ¹⁾	s	TVRK	Additional weight of flanges
125	125	185	165	10	394	400	195	145	116	8	8	3.0	0.3
160	160	230	200	10	394	400	230	180	116	8	8	3.4	0.4
200	200	270	240	10	394	400	270	220	116	8	8	3.6	0.5
250	250	320	290	10	394	400	320	270	216	12	8	4.2	0.6
315	315	395	350	10	594	600	385	335	216	12	10	6.0	0.7
400	400	475	445	10	594	600	470	420	216	16	10	10.0	1.6

1) n = Number of flange holes

Functional Description

Room temperature control

In VAV systems, the room temperature control takes the form of a cascade control. The primary controlled variable is the room temperature. The output signal of the room temperature controller is not fed directly to the supply air control damper but alters the setpoint value of the supply air flow rate control loop. The flow rate control also generates minimum and maximum limits for the air flow which has benefits in keeping the room temperature constant and for the functioning of the overall air conditioning system.

Flow rate measurement

A sensor is necessary for the positive measurement of air flows, this is achieved by pressure measurement at several points distributed over the cross-section and provision of the resulting average value. The TROX differential pressure sensor is an optimum solution in terms of economics and product technology. This sensor delivers exact results for most ventilation applications with normal upstream flow conditions.

Flow rate control

The volume flow is controlled in a closed control loop, i.e. measurement – comparison – control.

The controller receives the current actual value based on the pressure differential from the transducer. In most applications, the setpoint value comes from a room temperature controller. The controller compares the actual value with the setpoint value and alters the control signal to the damper actuator in the event of a difference between the two values.

Supply/extract air tracking control

The balance between supply and extract air flow rate has to be maintained in individual rooms and closed-off office areas.

Otherwise, annoying whistling noises can occur at door gaps, and the doors can be difficult to open.

In laboratory applications control of potentially contaminated extract air can be of paramount importance.

For these reasons the variation of extract air flow should be linked to the supply air to provide a tracking control.

System diagram

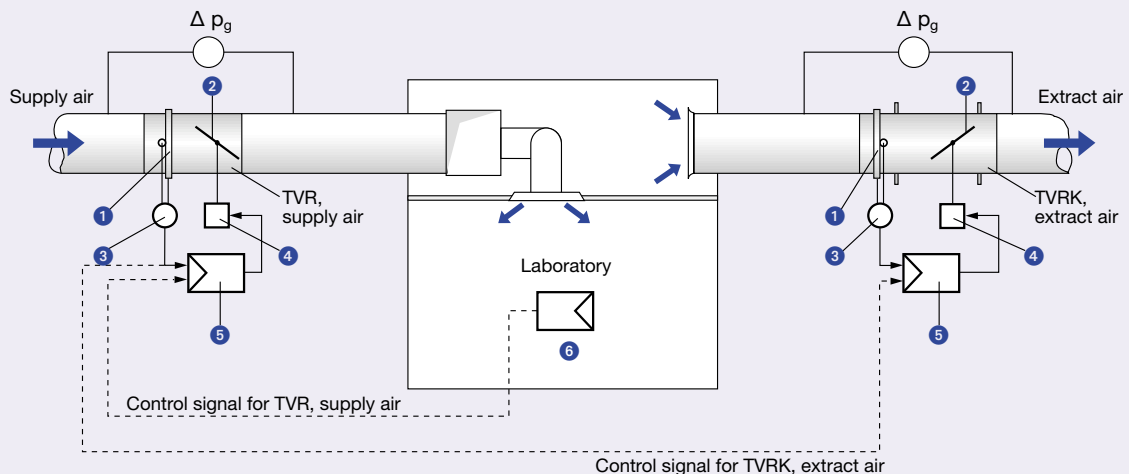

Legend

- ① Differential pressure sensor
- ② Control damper blade
- ③ Differential pressure transducer
- ④ Actuator
- ⑤ Flow rate controller
- ⑥ Room temperature controller (supplied by others)
- Wiring by others

Control diagram

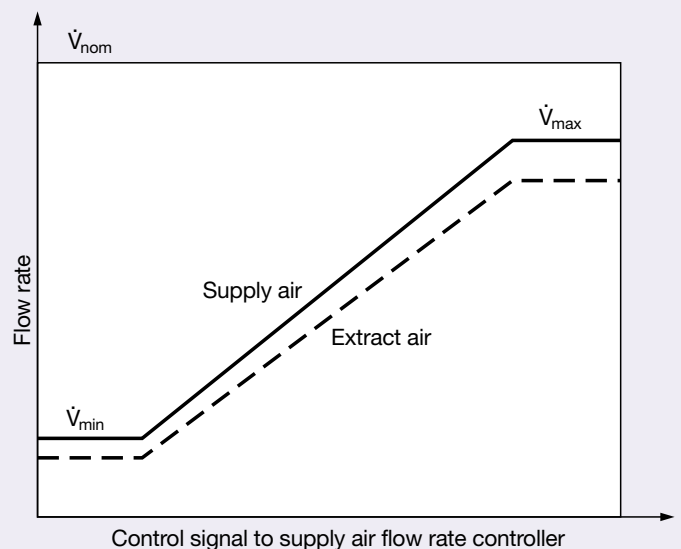

Aerodynamic and Acoustic Quick Selection

System attenuation in dB/oct. acc. to VDI 2081 (values incorporated into the quick selection table)

f_m in Hz	63	125	250	500	1000	2000	4000	8000
Duct bend attenuation	0	0	1	2	3	3	3	3
Room attenuation	5	5	5	5	5	5	5	5
End reflection	10	5	2	0	0	0	0	0

Correction for distribution into the duct system (values incorporated into the quick selection table)

\dot{V}	m ³ /h	500	1000	1500	2000	2500	3000	4000	5000	6000
	l/s	139	278	417	556	694	833	1111	1389	1667
dB per octave		0	3	5	6	7	8	9	10	11

Correction for other pressure differentials

Δp_g in Pa	100	200	400	600	800	1000
dB	-5	0	6	9	11	14

Quick selection of sound pressure level in dB(A) with $\Delta p_g = 200$ Pa

Nominal size	\dot{V}		$\Delta p_{g \min}$ in Pa		$\Delta \dot{V}^{2)}$	Air-regenerated noise					Case-radiated noise ³⁾
			TVRK	CAK ¹⁾		$\pm \%$	L_{pA}	L_{pA1}			
	without	with silencer Type CAK			500 mm			1000 mm	1500 mm		
125	25	90	20	-	9	35	19	12	7	18	
	60	216	30	-	7	45	30	23	19	29	
	105	378	60	5	6	52	38	32	28	36	
	150	540	90	10	5	57	42	36	32	41	
160	40	144	20	-	9	36	23	18	14	22	
	80	288	30	-	8	43	31	27	23	30	
	145	522	50	5	7	49	37	34	30	36	
	250	900	80	10	5	55	42	38	34	42	
200	65	234	20	-	9	45	34	29	25	35	
	180	648	30	-	7	46	35	30	27	36	
	310	1116	40	5	5	46	36	31	28	39	
	405	1458	70	10	5	45	34	31	29	41	
250	95	342	20	-	9	42	31	26	20	32	
	270	972	30	-	7	47	38	33	29	41	
	470	1692	40	5	5	48	38	33	30	43	
	615	2214	50	10	5	47	37	33	30	44	
315	155	558	20	-	9	40	30	26	22	31	
	425	1530	20	-	7	48	39	35	31	43	
	740	2664	30	5	6	51	42	38	35	48	
	1025	3690	40	10	5	54	46	42	38	52	
400	255	918	20	-	9	29	19	15	12	20	
	715	2574	20	-	7	39	32	27	25	36	
	1250	4500	30	5	6	47	40	36	33	46	
	1680	6048	40	10	5	52	46	42	39	53	

1) must be allowed for based on a length of 1000 mm

2) typical values

3) 4 dB/octave ceiling reduction and 5 dB/octave room attenuation have been allowed for in the calculation of case-radiated noise.

Air-regenerated Noise

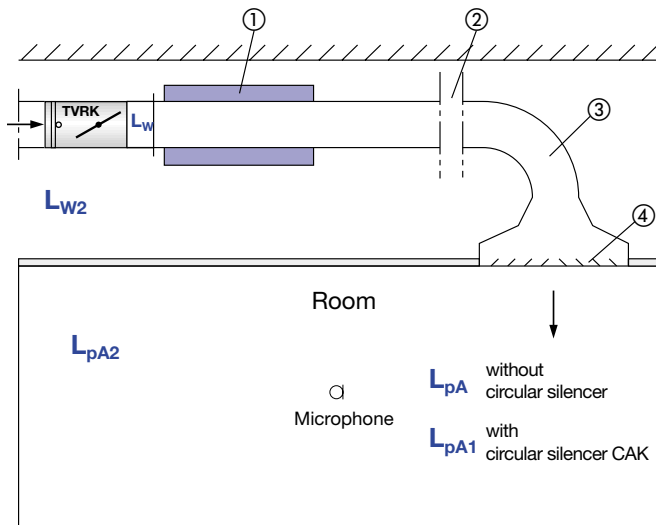

- ① Circular silencer CAK
- ② Air distribution to several diffusers
- ③ Duct bend
- ④ End reflection based on diffuser

Nomenclature, see page 4

Air-regenerated noise

Nominal size	\dot{V}		$\Delta p_g = 100 \text{ Pa}$								$\Delta p_g = 200 \text{ Pa}$								$\Delta p_g = 500 \text{ Pa}$							
			L_w in dB								L_w in dB								L_w in dB							
			f_m in Hz								f_m in Hz								f_m in Hz							
			63	125	250	500	1000	2000	4000	8000	63	125	250	500	1000	2000	4000	8000	63	125	250	500	1000	2000	4000	8000
l/s	m ³ /h																									
125	25	90	48	44	41	38	36	27	18	18	31	35	31	40	41	38	30	20	32	40	43	47	48	46	42	34
	60	216	57	60	51	47	48	39	31	27	42	52	49	48	50	47	41	30	42	55	54	53	54	51	46	37
	105	378	64	67	59	54	56	44	37	31	49	61	58	55	58	51	45	38	51	64	62	58	60	56	52	43
	150	540	63	67	61	56	60	49	42	38	55	63	65	62	64	56	50	43	55	69	70	65	66	60	55	48
160	40	144	48	47	40	38	38	32	19	17	31	40	40	41	41	40	31	25	31	41	43	45	45	45	41	36
	80	288	60	57	47	45	46	39	28	21	48	51	50	48	48	45	38	33	46	52	55	53	51	49	45	41
	145	522	64	64	55	52	54	43	35	31	53	60	54	53	56	50	43	41	53	62	62	60	58	54	50	47
	250	900	65	66	61	58	59	49	43	40	58	64	63	62	63	56	49	46	62	68	69	65	65	60	54	52
200	65	234	56	52	48	46	46	38	31	23	47	52	50	50	45	42	36	47	55	56	55	54	50	48	47	
	180	648	56	55	50	48	48	37	30	27	49	54	51	52	52	47	44	38	53	59	59	58	57	53	50	48
	310	1116	46	51	51	45	42	37	29	27	52	58	57	58	58	51	46	43	61	66	63	62	61	58	53	50
	405	1458	42	49	52	44	38	37	29	27	49	54	56	58	62	52	47	43	63	68	67	65	65	60	55	54
250	95	342	52	46	41	42	39	36	26	16	40	44	45	44	46	48	39	31	44	46	48	49	50	54	52	51
	270	972	59	58	52	55	46	40	33	27	51	56	53	55	54	53	46	39	52	61	60	58	56	57	54	48
	470	1692	50	51	50	50	47	43	37	29	55	63	60	63	58	53	47	41	62	69	65	64	63	62	58	51
	615	2214	45	48	49	48	48	45	39	31	52	61	62	65	60	56	51	47	64	70	69	68	66	63	58	52
315	155	558	48	45	40	38	43	31	22	19	44	45	48	45	48	48	39	31	42	43	49	51	51	52	48	47
	425	1530	67	59	53	55	51	46	42	32	61	59	57	57	57	53	52	44	61	61	61	59	59	57	56	52
	740	2664	70	67	61	63	57	50	47	41	65	65	63	64	62	57	55	48	68	69	68	65	65	62	62	56
	1025	3690	71	66	67	67	62	55	51	47	69	67	70	69	67	61	58	53	74	73	74	70	70	66	64	59
400	255	918	49	46	47	41	43	32	24	19	46	47	49	46	47	46	38	31	42	47	53	52	51	62	51	48
	715	2574	63	56	56	56	50	46	40	38	61	58	58	58	56	54	50	45	61	62	62	60	59	59	56	53
	1250	4500	68	65	65	64	56	52	48	48	65	67	66	66	63	59	55	50	68	70	69	67	66	64	62	56
	1680	6048	73	65	69	67	60	56	53	50	68	67	72	70	66	61	58	52	73	72	74	71	70	67	64	58

Case-radiated Noise

Example

Given: $\dot{V}_{\max} = 145 \text{ l/s}$ or $522 \text{ m}^3/\text{h}$
 $\Delta p_g = 200 \text{ Pa}$
 Specified sound pressure level in the room 38 dB(A)
 For further assumptions, see calculation procedure

Calculation procedure

Quick selection:
 TVRK 160
 $L_{pA2} = 36 \text{ dB(A)}$

Case-radiated noise calculation procedure

f_m	63	125	250	500	1000	2000	4000	8000
L_W (page 7)	53	60	54	53	56	50	43	41
ΔL_W	18	22	24	26	21	10	4	6
L_{W2}	35	38	30	27	35	40	39	35
Ceiling attenuation	4	4	4	4	4	4	4	4
Room attenuation	6	6	5	5	4	4	4	4
Sound power level to room	25	28	21	18	27	32	31	27
A-weighting	-26	-16	-9	-3	0	1	1	-1
Corrected level	-1	12	12	15	27	33	32	26

Result: L_{pA2} approx. **37 dB(A)**

Correction values for case-radiated noise in dB

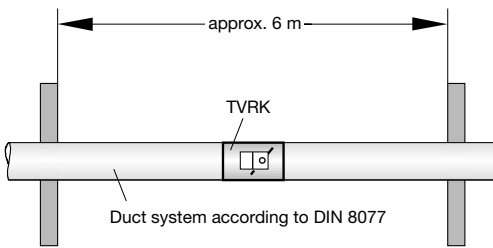
Installation configuration	ΔL_W	Nominal size	ΔL_W in dB, based on f_m in Hz							
			63	125	250	500	1000	2000	4000	8000
TVRK $L_{W2} = L_W - \Delta L_W$  Duct system according to DIN 8077	ΔL_W	125	15	26	24	27	25	13	6	2
		160	18	22	24	26	21	10	4	6
		200	15	17	18	15	11	7	6	10
		250	6	16	18	17	12	9	12	10
		315	14	17	20	17	11	6	12	8
		400	17	19	20	13	9	9	13	12

Specification text *

Circular VAV controller in PPs plastic for variable volume flow systems, in 6 nominal sizes. Suitable for the flow rate or differential pressure control for use with aggressive media as all parts in contact with the air flow are made of plastic (no metal components).

Special characteristics:

- Integral differential pressure sensor with 3 mm measurement holes, slides out for inspection
- Factory set up of flow rate of each unit. This includes functional testing using a dedicated test rig. Data covering set up is given on a test label attached to each box.
- The actual value signal is referred to the nominal flow rate so simplifying any subsequent adjustment to flow rate.

Spigot connections suitable for circular connecting ducts to DIN 8077, casing air leakage complies with DIN EN 1751, class B.

Differential pressure range 20 to 1500 Pa, flow rate range depending on type of controller approx. 7 : 1.

Controls:

- Variable flow rate control, electronic controller for the connection of an external control signal, actual value signal relative to \dot{V}_{nom}
- Supply voltage 24 VAC
- Signal voltage 2 to 10 VDC
- Static differential pressure measurement

Materials:

Casing and damper blade in polypropylene (PPs), flame resistant, plain bearings in polypropylene (PP), damper blade seal in chloroprene rubber (CR), plastic grid (PP)

* Text for standard construction

For control components, see design programme or price list

Order code

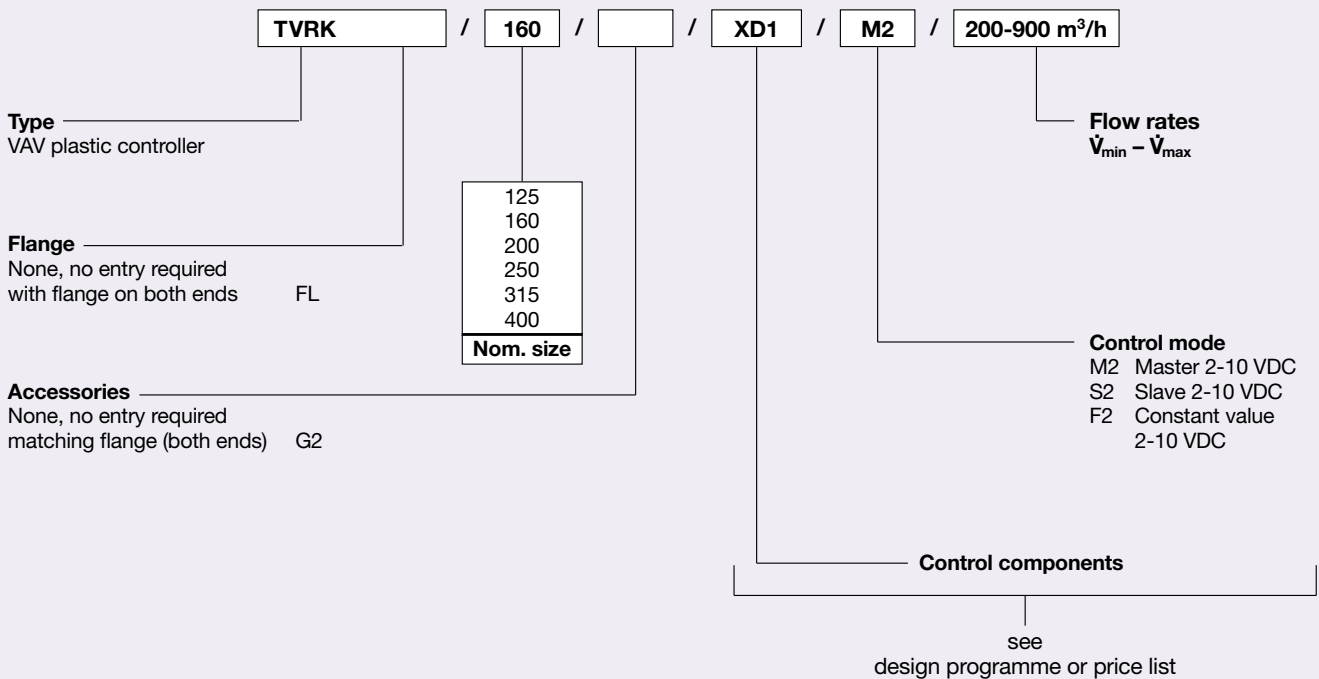

Order example

Make: TROX
 Type: TVRK / 160 / XD1 / M2 / 200-900 m³/h

