

VARYCONTROL VAV Controller

Type TVJ-Easy · TVT-Easy



TROX[®] TECHNİK

The art of handling air

Contents

Innovation _____	3	Acoustic quick selection _____	8
Construction · Dimensions _____	4	Flow rate adjustment _____	9
Dimensions _____	5	Characteristics · Wiring examples _____	10
Technical data · Nomenclature _____	6	Order details _____	11
Selection of dimensions _____	7		

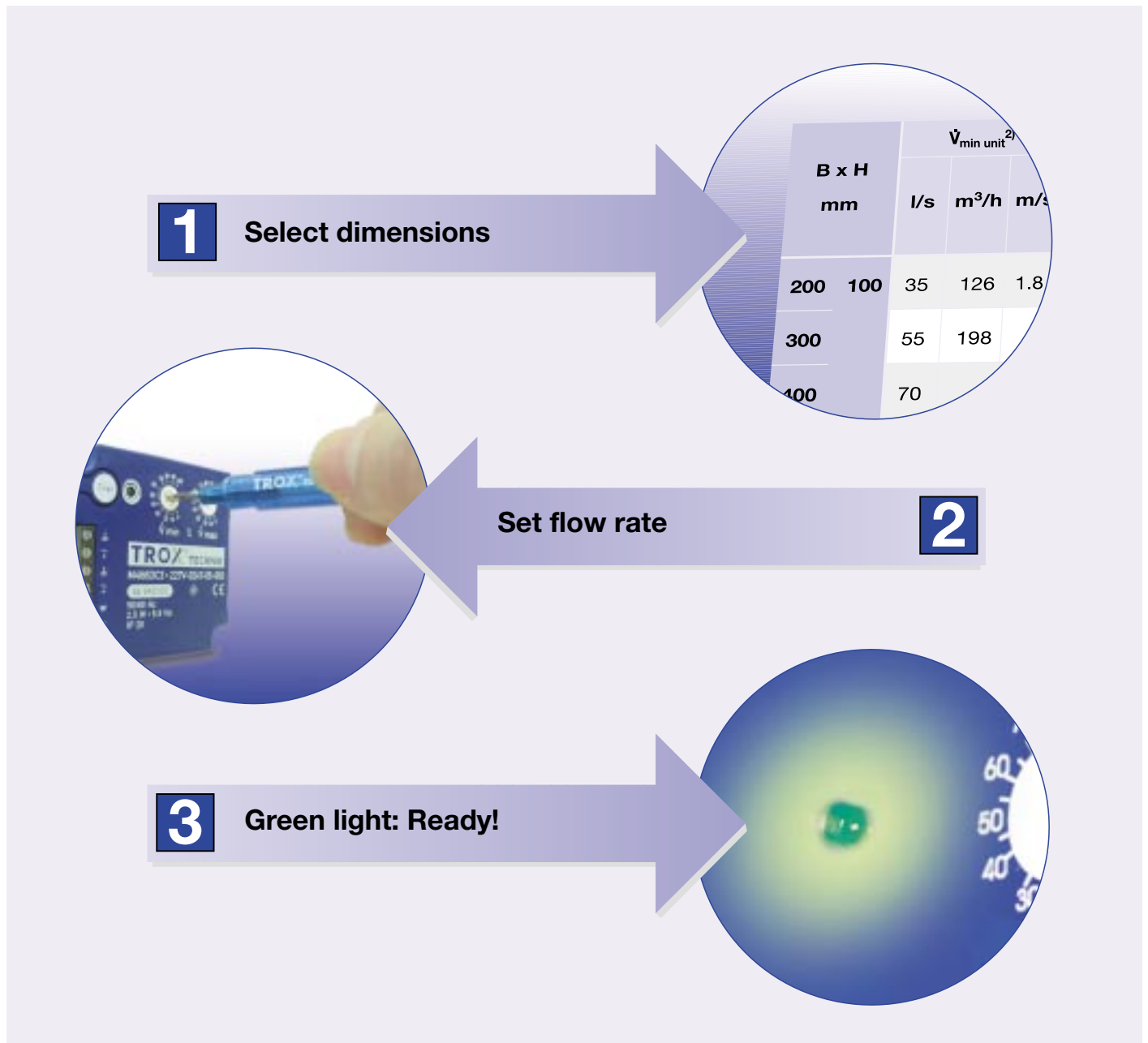

TROX TVJ-/TVT-Easy – the innovative solution

- **Easy** Selection according to duct dimensions
- **Easy** Flow rate adjustment without adjustment tool
- **Easy** Functional testing with service button
- **Easy** Functional check by indicator light

The proven technology of the compact flow rate controller has been optimized. Valuable on site time saved by simple set up.

TVJ-/TVT-Easy, developed with consultants and customers!

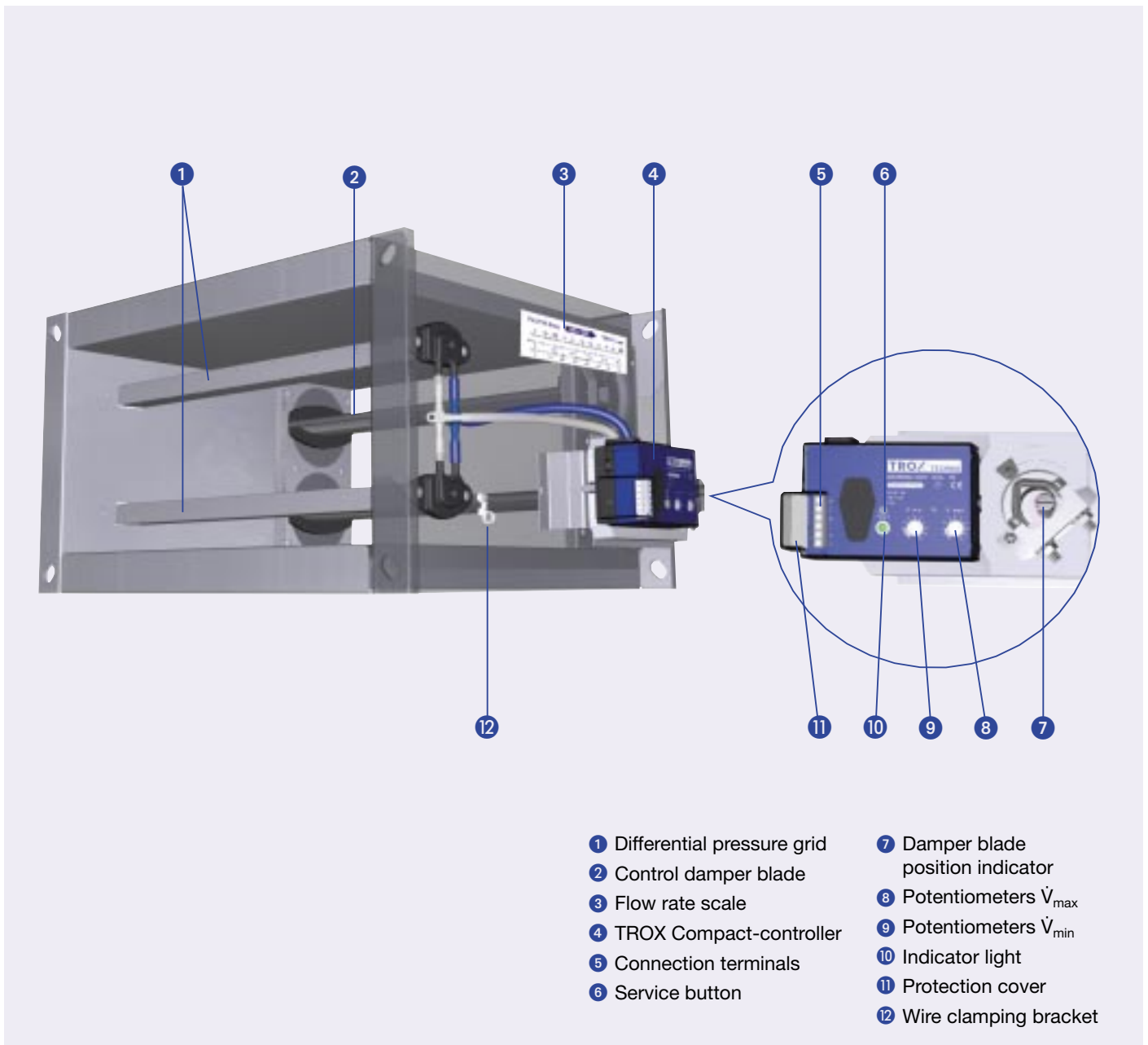

- | | |
|------------------------------|-----------------------------------|
| 1 Differential pressure grid | 7 Damper blade position indicator |
| 2 Control damper blade | 8 Potentiometers \dot{V}_{\max} |
| 3 Flow rate scale | 9 Potentiometers \dot{V}_{\min} |
| 4 TROX Compact-controller | 10 Indicator light |
| 5 Connection terminals | 11 Protection cover |
| 6 Service button | 12 Wire clamping bracket |

Construction · Dimensions

Characteristics

- Electronic flow rate control
- Green indicator light provides functional information:
 - permanently on = set
 - blinking = not set
 - off = no supply voltage
- Functional testing as follows:
 - Press service button for at least 1 second
 - Actuator opens damper blade
 - Actuator closes damper blade
 - Actuator returns damper blade to previous position
- High level of control accuracy for the flow rate settings, please ensure the most favourable aerodynamic configuration of ductwork is used
- Transparent protection cover to prevent inadvertent resetting and provide general security
- Clamping bracket for wiring
- Differential pressure range 20 to 1000 Pa
- Suitable for non-aggressive air
- Independent of orientation
- TVT: Closed blade air leakage complies with EN 1751, class 4 (B > 600 class 3), also complies with the requirements of DIN 1946, part 4

- For delivery, control damper blade in 45° position
- Flange both ends, suitable for fitting system 30 connecting profiles
- Casing air leakage flow rate complies with DIN EN 1751, class A
- The mechanical components are maintenance-free
- Operating temperature range 10 to 50 °C
- Storage temperature range -20 to +80 °C

General information

- Standard filtration in air-conditioning systems allows the use of TROX Compact-controllers for the supply air without additional dust protection filters. Since a small volume flow is passed through the transducer in order to measure the flow rate, the following must be noted:
- With heavy dust levels in the room, suitable extract air filters must be provided.
 - If the air is contaminated with fluff or sticky particles or contains aggressive media, units should be selected with the on-line design programme "Air terminal units".

TVJ-Easy · TVT-Easy

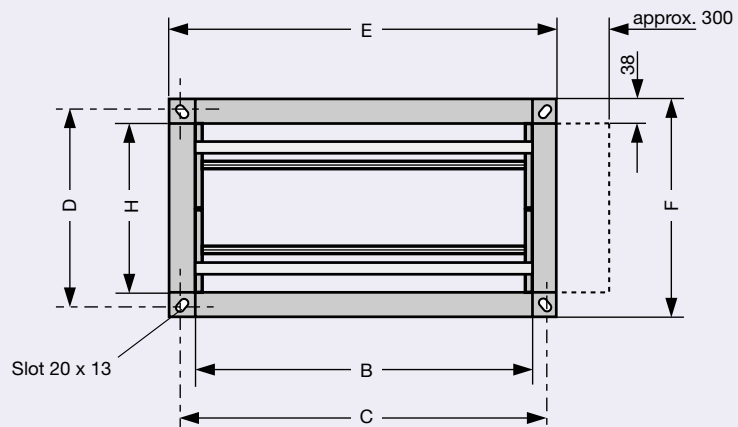
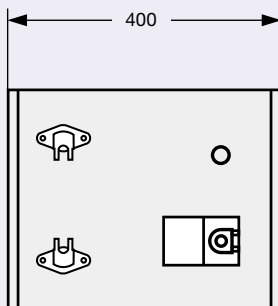

TVJD-Easy · TVTD-Easy

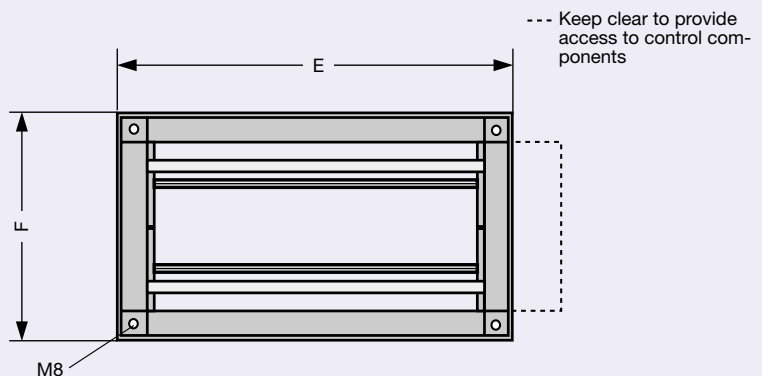
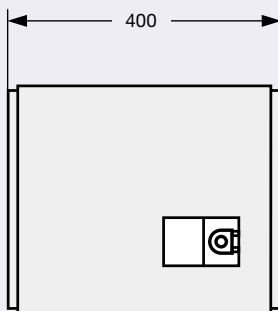

Rectangular duct connection

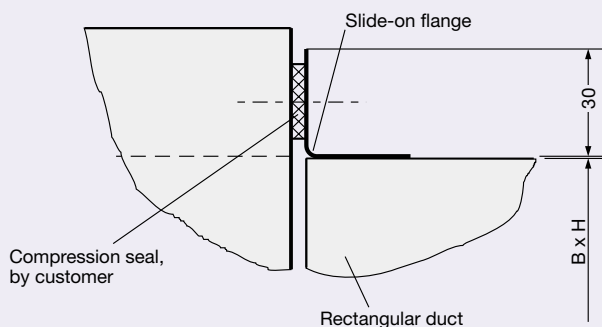

Please refer to leaflet no. 5/4/EN/.. for further details concerning the characteristics and the dimensions of the TX secondary silencer.

Dimensions

B x H mm		Dimensions in mm								Weight in kg		
		TVJ-/TVT-Easy				TVJD-/TVTD-Easy				Weight		
		C	D	E	F	C	D	E	F	TVJ-/ TVT-Easy	TVJD-/ TVTD-Easy	TX
200	100	234	134	276	176	234	134	280	180	6	9	10
	300	334	134	376	176	334	134	380	180	7	11	12
	400	434	134	476	176	434	134	480	180	8	12	15
	500	534	134	576	176	534	134	580	180	9	14	17
	600	634	134	676	176	634	134	680	180	10	15	20
200	200	234	234	276	276	234	234	280	280	9	14	16
	300	334	234	376	276	334	234	380	280	10	15	20
	400	434	234	476	276	434	234	480	280	11	17	25
	500	534	234	576	276	534	234	580	280	12	18	29
	600	634	234	676	276	634	234	680	280	13	20	34
	700	734	234	776	276	734	234	780	280	14	21	39
	800	834	234	876	276	834	234	880	280	15	23	44
300	300	334	334	376	376	334	334	380	380	10	15	24
	400	434	334	476	376	434	334	480	380	11	17	29
	500	534	334	576	376	534	334	580	380	12	18	34
	600	634	334	676	376	634	334	680	380	13	20	40
	700	734	334	776	376	734	334	780	380	15	22	45
	800	834	334	876	376	834	334	880	380	16	24	50
	900	934	334	976	376	934	334	980	380	18	26	55
	1000	1034	334	1076	376	1034	334	1080	380	19	29	60
400	400	434	434	476	476	434	434	480	480	14	21	34
	500	534	434	576	476	534	434	580	480	15	23	39
	600	634	434	676	476	634	434	680	480	16	24	45
	700	734	434	776	476	734	434	780	480	17	26	50
	800	834	434	876	476	834	434	880	480	18	27	56
	900	934	434	976	476	934	434	980	480	20	29	61
	1000	1034	434	1076	476	1034	434	1080	480	21	32	67
500	500	534	534	576	576	534	534	580	580	19	28	45
	600	634	534	676	576	634	534	680	580	20	30	50
	700	734	534	776	576	734	534	780	580	22	32	56
	800	834	534	876	576	834	534	880	580	23	35	62
	900	934	534	976	576	934	534	980	580	25	37	68
	1000	1034	534	1076	576	1034	534	1080	580	26	39	73
		TVJ-Easy				TVJD-Easy				TVJ-Easy	TVJD-Easy	TX
600	600	634	634	676	676	634	634	680	680	19	29	55
	800	834	634	876	676	834	634	880	680	23	35	67
	1000	1034	634	1076	676	1034	634	1080	680	27	41	80
800	800	834	834	876	876	834	834	880	880	28	42	79
	1000	1034	834	1076	876	1034	834	1080	880	32	48	93
1000	1000	1034	1034	1076	1076	1034	1034	1080	1080	38	57	107

TROX Compact-controller technical data

Supply voltage:	24 VAC \pm 20 %, 50/60 Hz or 24 VDC \pm 10 %
Power rating:	max. 5 VA (for a.c. voltage) max. 3 W (for d.c. voltage)
Control signal:	0 to 10 VDC, Ri > 100 k Ω
Flow rate actual value signal:	0 to 10 VDC linear, max. 0.5 mA
Transducer range:	2 to 300 Pa
Running time:	120 to 300 sec. for 87°
Torque:	15 Nm
Safety class:	III (Save voltage)
Protection level:	min. IP 20



Additional safety requirements for the TROX Compact-controller

- Installation and assembly must be performed by qualified personnel. Assembly must be carried out in compliance with local legal regulations.
- Connect only to a safety transformer.
- The air terminal units of the TROX-Easy type with TROX Compact-controllers may not be used outside of their standard area of application (air conditioning systems). Use in aircraft is not allowed.

Nomenclature

f_m	in Hz: Octave band centre frequency
L_{pA}	in dB(A): A-weighted sound pressure level of air-regenerated noise in the room, system attenuation taken into account
L_{pA1}	in dB(A): A-weighted sound pressure level of air-regenerated noise in the room with TX secondary silencer, system attenuation taken into account
L_{pA2}	in dB(A): A-weighted sound pressure level of case-radiated noise in the room, system attenuation taken into account
L_{pA3}	in dB(A): A-weighted sound pressure level of case-radiated noise in the room with additional acoustic cladding, system attenuation taken into account
\dot{V}_{Nom}	in m ³ /h or l/s: Nominal flow rate
\dot{V}	in m ³ /h or l/s: Flow rate
$\Delta \dot{V}$	in \pm %: Flow rate tolerance from setpoint value
$\dot{V}_{min\ unit}$	in m ³ /h or l/s: Minimum unit flow rate
\dot{V}_{max}	in m ³ /h or l/s: Maximum flow rate setpoint
\dot{V}_{min}	in m ³ /h or l/s: Minimum flow rate setpoint
Δp_g	in Pa: Total pressure differential
$\Delta p_{g\ min}$	in Pa: Minimum total pressure differential
v	in m/s: Velocity in the duct system
U	in Volt: Actual value signal output (0 to 10 VDC)
w	in Volt: Control signal input (0 to 10 VDC)
$\perp, -$: Ground, neutral
$\sim, +$: 24 V supply voltage

All sound pressure levels are based on 20 μ Pa.

All noise levels measured in a reverberation chamber.

Selection of Dimensions

- The selection of the dimensions takes place according to the flow rate range specified by the consultant.
- The accurate adjustment of the flow rate setpoints is carried out using a flow rate scale, which is attached on each controller.

For the acoustic characteristics in tables on page 8, duct air velocity is needed. This can be determined from the following table.

Minimum total pressure differentials and flow rate tolerance			
m/s	$\Delta \dot{V}$ in \pm %	$\Delta p_{g \text{ min}}$ in Pa	
		TVJ-/TVT-Easy	TX ¹⁾
2	14	20	5
4	8	20	20
7	5	30	55
10	5	40	115

1) Additional factor to be taken into account

Flow rate ranges																							
B x H		$\dot{V}_{\text{min unit}^{2)}$			\dot{V}_{Nom}			B x H		$\dot{V}_{\text{min unit}^{2)}$			\dot{V}_{Nom}			B x H		$\dot{V}_{\text{min unit}^{2)}$			\dot{V}_{Nom}		
mm		l/s	m ³ /h	m/s	l/s	m ³ /h	m/s	mm		l/s	m ³ /h	m/s	l/s	m ³ /h	m/s	mm		l/s	m ³ /h	m/s	l/s	m ³ /h	m/s
200	100	35	126	1.8	180	648	9.0	300	300	175	630	2.0	880	3168	9.8	500	500	475	1710	1.9	2365	8514	9.5
300		55	198	1.8	270	972	9.0	400		235	846	2.0	1175	4230	9.8	600		570	2052	1.9	2840	10224	9.5
400		70	252	1.8	360	1296	9.0	500		295	1062	2.0	1470	5292	9.8	700		665	2394	1.9	3315	11934	9.5
500		90	324	1.8	450	1620	9.0	600		355	1278	2.0	1765	6354	9.8	800		755	2718	1.9	3785	13626	9.5
600		110	396	1.8	540	1944	9.0	700		410	1476	2.0	2055	7398	9.8	900		850	3060	1.9	4260	15336	9.5
200	200	70	252	1.8	360	1296	9.0	800		470	1692	2.0	2350	8460	9.8	1000		945	3402	1.9	4735	17046	9.5
300		110	396	1.8	540	1944	9.0	900		530	1908	2.0	2645	9522	9.8	Dimensions H = 600, 800 and 1000 only available as TVJ-/TVJD-Easy!							
400		145	522	1.8	720	2592	9.0	1000		590	2124	2.0	2940	10584	9.8								
500		180	648	1.8	895	3222	9.0	400	400	325	1170	2.0	1635	5886	10.2	600	600	705	2538	2.0	3525	12690	9.8
600		215	774	1.8	1075	3870	9.0	500		410	1476	2.0	2040	7344	10.2	800		940	3384	2.0	4700	16920	9.8
700		250	900	1.8	1250	4500	9.0	600		490	1764	2.0	2450	8820	10.2	1000		1175	4230	2.0	5880	21168	9.8
800		285	1026	1.8	1435	5166	9.0	700		570	2052	2.0	2860	10296	10.2	800	800	1305	4698	2.0	6535	23526	10.2
								800		655	2358	2.0	3265	11754	10.2	1000		1635	5886	2.0	8160	29394	10.2
								900		735	2646	2.0	3675	13230	10.2	1000	1000	2090	7524	2.1	10455	37638	10.5
								1000		815	2934	2.0	4085	14706	10.2								

2) 20 % of \dot{V}_{Nom}

Acoustic Quick Selection

System attenuation in dB/Oct. acc. to VDI 2081 (values incorporated into the quick selection table)

f_m in Hz	63	125	250	500	1000	2000	4000	8000
Duct attenuation	0	0	1	2	3	3	3	3
Room attenuation	5	5	5	5	5	5	5	5
End reflection	10	5	2	0	0	0	0	0

Correction for distribution into the duct system (values incorporated into the quick selection table)

\dot{V}	l/s	150	300	600	1400	2800	4200	5600	6700	7800	8900	10000
	m ³ /h	540	1080	2160	5040	10080	15120	20160	24120	28080	32040	36000
dB per octave		0	3	6	10	13	14	16	17	17	18	19

Correction for other widths

Δp_g	Width B	Reference B = 600 mm									Reference B = 1000 mm		
		200	300	400	500	600	700	800	900	1000	800	900	1000
100 Pa	100 Pa	-4	-2	-2	-1	0	1	1	1	2	-1	-1	0
	200 Pa	-4	-3	-2	-1	0	1	1	2	2	-1	0	0
	500 Pa	-4	-2	-1	-1	0	1	1	2	3	-1	-1	0

Quick Selection of sound pressure level in dB(A)

B x H mm	v m/s	$\Delta p_g = 100$ Pa				$\Delta p_g = 200$ Pa				$\Delta p_g = 500$ Pa				
		Air-regenerated noise		Case-radiated noise ¹⁾		Air-regenerated noise		Case-radiated noise ¹⁾		Air-regenerated noise		Case-radiated noise ¹⁾		
		L_{pA}	L_{pA1}	L_{pA2}	L_{pA3}	L_{pA}	L_{pA1}	L_{pA2}	L_{pA3}	L_{pA}	L_{pA1}	L_{pA2}	L_{pA3}	
		without silencer	with silencer type TX	without acoustic cladding	with acoustic cladding	without silencer	with silencer type TX	without acoustic cladding	with acoustic cladding	without silencer	with silencer type TX	without acoustic cladding	with acoustic cladding	
600	100	2	43	20	30	19	49	23	35	24	60	32	46	33
		4	44	26	34	26	50	29	39	30	60	36	48	37
		7	44	32	39	33	51	35	43	35	59	40	51	42
		10	45	39	43	37	51	40	46	39	59	44	54	47
	200	2	43	20	32	22	49	24	38	26	60	32	48	35
		4	43	25	37	29	50	29	42	33	59	36	50	40
		7	44	32	42	36	50	35	46	39	58	41	54	46
		10	44	39	45	40	50	40	49	43	58	45	57	50
	300	2	42	20	33	23	49	24	39	28	60	32	49	37
		4	43	25	38	31	49	29	44	35	59	37	52	42
		7	43	32	43	37	50	35	48	41	58	42	56	48
		10	44	39	47	42	50	40	51	45	58	45	60	52
400	2	42	19	34	24	49	24	40	29	60	32	50	38	
	4	43	24	39	32	49	29	45	36	58	37	53	43	
	7	43	32	45	39	49	35	49	42	58	43	58	50	
	10	44	39	49	43	48	40	50	43	59	46	62	54	
500	2	42	19	35	25	48	24	41	30	59	32	51	39	
	4	42	24	40	33	49	29	46	37	58	38	55	45	
	7	43	32	46	40	49	35	50	43	58	43	59	51	
	10	44	39	50	44	48	40	51	44	59	46	63	56	
600	2	42	19	36	26	48	24	42	31	59	32	52	40	
	4	42	24	41	34	49	29	46	38	58	38	55	46	
	7	43	32	46	41	49	35	51	44	58	43	60	52	
	10	44	39	50	45	48	40	52	45	59	47	64	57	
1000	800	2	41	18	39	30	48	24	45	35	59	34	55	44
		4	42	23	45	38	48	29	50	42	58	40	60	51
		7	43	31	50	45	49	35	55	48	59	45	66	58
		10	44	39	54	49	47	40	55	49	61	48	70	63
1000	1000	2	41	18	40	31	47	24	46	36	58	35	56	45
		4	42	23	46	39	48	29	51	43	58	41	62	53
		7	43	31	51	46	48	35	56	49	59	46	68	60
		10	44	39	56	50	47	40	56	50	61	49	72	64

1) 4 dB/octave ceiling reduction and 5 dB/octave room attenuation have been allowed for in the calculation of case-radiated noise. Acoustic data for differential pressure up to 1000 Pa, see on-line design programme "Air terminal units".

Please refer to leaflet no. 5/4/EN/.. for acoustic performance data and selection example.

Flow Rate Adjustment

TVJ-/TVT-Easy

500 x 200

TROX® TECHNIK

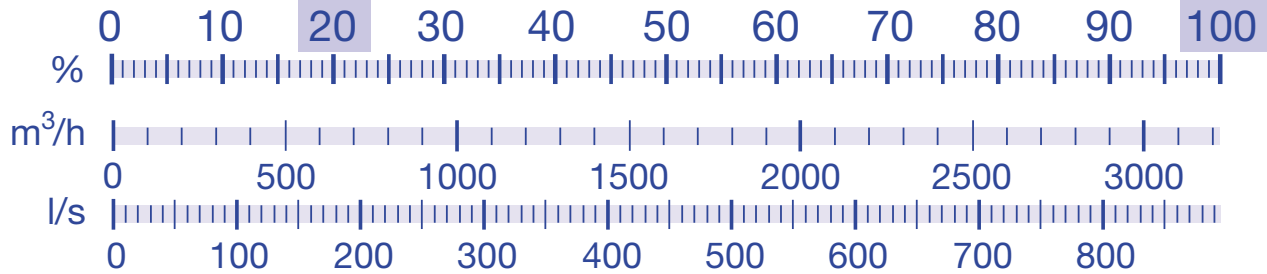

On each TVJ-/TVT-Easy, a flow rate scale is available in order to determine the settings on site (see example size 500 x 200).

Variable flow rate control

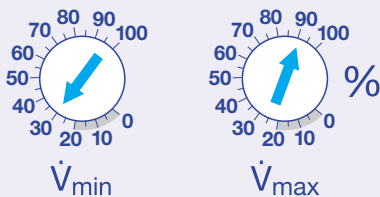

The required flow rates must be adjusted by the customer. If \dot{V}_{\min} is set higher than \dot{V}_{\max} , then \dot{V}_{\min} is provided as a constant flow rate, even if a control signal is transmitted. If \dot{V}_{\min} is set on 0 %, then control is between shut-off and \dot{V}_{\max} . If the control signal falls below 0.1 VDC, the control damper closes.

Constant flow rate control

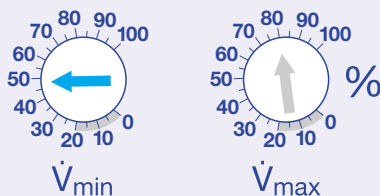

The constant flow rate can be set with the \dot{V}_{\min} -potentiometer. The setting of the \dot{V}_{\max} -potentiometer is unimportant.

BMS operation

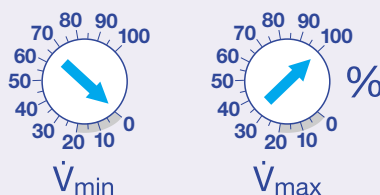

If the flow rate is set by the BMS, the \dot{V}_{\min} -potentiometer must be set at 0 % and the \dot{V}_{\max} -potentiometer must be set at 100 %. If the control signal falls below 0.1 VDC, the control damper closes.

Factory setting

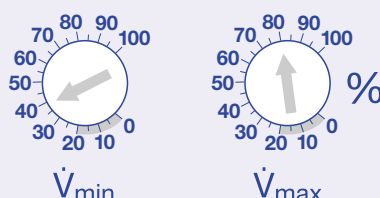

For delivery, settings are, $\dot{V}_{\min} = 40 \%$ and $\dot{V}_{\max} = 80 \%$.

Characteristics · Wiring Examples

Characteristics of the control signal (Example)

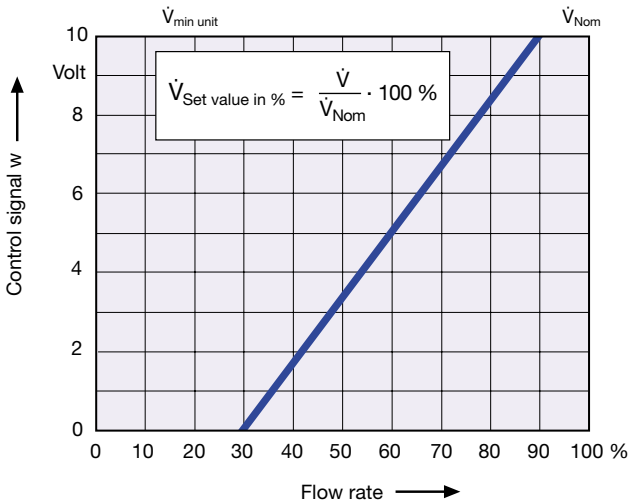

Characteristic of actual value signal

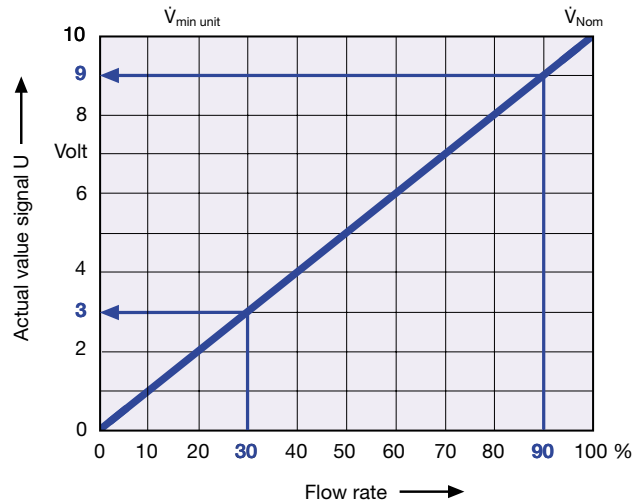

Variable flow rate control

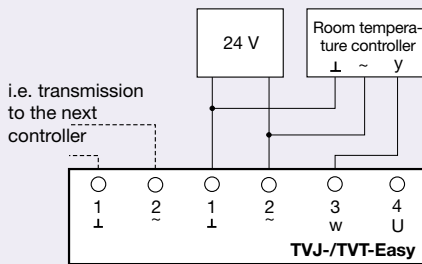

The connection of supply voltage and of the external room temperature controller must be carried out as shown in the circuit diagram opposite.

Constant flow rate control

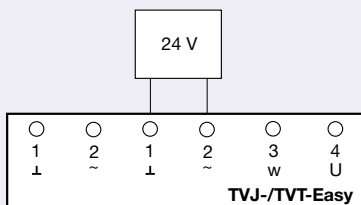

As soon as the 24 V supply voltage is applied, the controller runs the set \dot{V}_{min} -value as a constant flow rate.

$\dot{V}_{\text{min}} / \dot{V}_{\text{max}}$ changeover

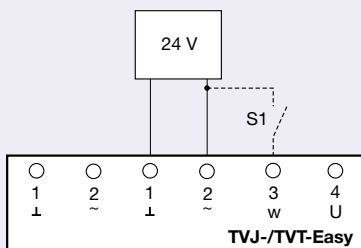

The switch S1 enables a changeover between the two constant flow rates of \dot{V}_{min} and \dot{V}_{max} .

Switch S1 open : \dot{V}_{min}
Switch S1 closed : \dot{V}_{max}

When there is parallel connection of multiple TVJ-Easy/TVT-Easy controllers, the switch S1 must be used as changeover switch and the contact for the \dot{V}_{min} operation must be connected to the ground (terminal 1).

Override controls OPEN / CLOSED

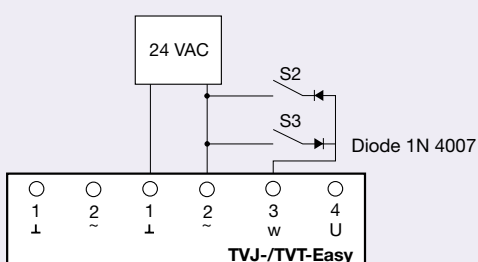

The override controls to provide OPEN and CLOSED can be achieved using external switches (potential-free contacts), only for a.c. voltage.

Switch S2 closed: Damper blade CLOSED
Switch S3 closed: Damper blade OPEN

All override controls can be combined among themselves and with the different circuit options.

The customer made connections and wiring must comply with the local standards for electrical wiring!

Specification text

Make: TROX. VAV rectangular controller Type TVJ-Easy or TVT-Easy (for low leakage shut-off) for variable air volume flow systems, for supply air or extract air, in 39 sizes.

Selection based on duct dimensions. Simple setting by the customers of the volume flow with \dot{V}_{\min} - and \dot{V}_{\max} -adjustment potentiometers with percentage scales. During the installation or commissioning of controller, adjustment is possible without supply voltage. A transparent protection cover prevents inadvertent resetting and provides general security. Control damper blade delivery is in 45° position in order to allow ventilation air flow without additional control functions.

Special characteristics:

- Flow rate adjustment without adjustment tool
- Functional testing with service button
- Functional check by indicator light
- Factory functional testing of each unit using a dedicated test rig

High visibility external indicator light for signalling the functions:

Set, not set and power failure.

Functional testing of actuator 'CLOSED, OPEN and control operation' possible with service button.

Electrical connections with screw terminals, terminal for looping the 24 V supply voltage, i.e. for the connection of simple voltage transmission to the next controller. Wire clamping bracket fixed to the casing.

Voltage range for control and actual value signal 0 to 10 VDC.

Possible override controls with external switches using potential-free contacts: CLOSED, OPEN, \dot{V}_{\min} or \dot{V}_{\max} .

Integral differential pressure sensor with 3 mm measurement holes which are, to a large extent resistant to contamination. Position of the damper blade visible externally based on shaft extension. TROX Compact electronic flow rate controller factory fitted. TVT: Closed blade air leakage complies with EN 1751, class 4 (B > 600 class 3), also complies with the requirements of DIN 1946, part 4. Differential pressure range 20 to 1000 Pa.

Materials:

Casing in galvanised sheet steel, aluminium sensor tubes and blades, gear wheels made of antistatic plastic (ABS), heat resistant up to 50 °C.

Unit variant with:

Additional acoustic cladding to reduce case-radiated noise. Consists of 40 mm mineral wool and outer cover of galvanised sheet steel. This gives a reduction in case-radiated noise of minimum 6 dB providing the upstream and downstream ducting has a rigid external insulation. Non-retrofitable.

Optionally with:

TX secondary silencer, for the reduction of air regenerated noise, insertion loss approx. 9 dB at 250 Hz. Lining of mineral wool conforming to DIN 4102, fire rating class A2, with RAL-quality mark RAL-GZ 388, bio-degradable pursuant to TRGS 905 and EU directive 97/69/EG. Mineral wool faced with fibreglass as protection against erosion, suitable for air velocities up to 20 m/s, inert to fungal and bacterial growth.

Order code TVJ-Easy · TVT-Easy

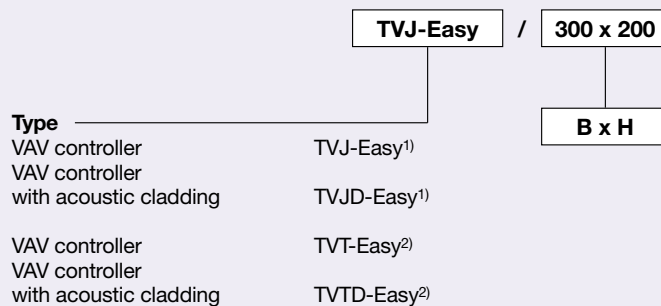

1) control damper closed blade leakage complies with DIN EN 1751, class 1

2) control damper closed blade leakage complies with DIN EN 1751, class 4 and 3

Order code TX

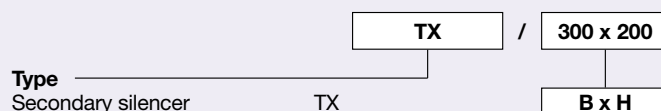

Order example TVJ-Easy · TVT-Easy

Make: TROX
 Type: TVJ-Easy / 300 x 200

Order example TX

Make: TROX
 Type: TX / 300 x 200

